



# **A Quick Overview of Vector-Borne Diseases**

**Marco E. Metzger, PhD**  
**Vector-Borne Disease Section**  
**California Department of Public Health**



**April 2019 VBDS Staff Meeting**

# Offices of CDPH Vector-Borne Disease Section

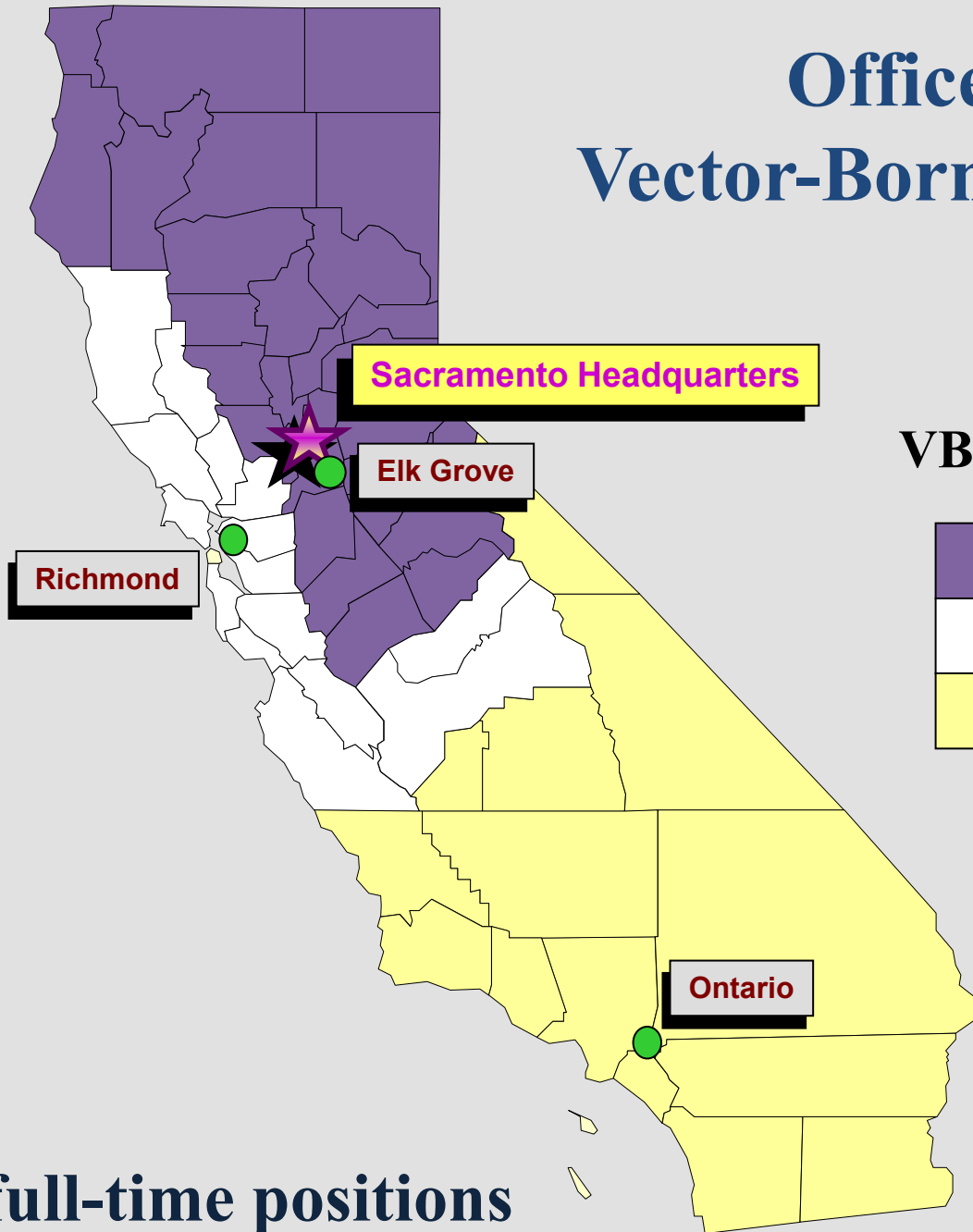

**Sacramento Headquarters**

**Elk Grove**

**Richmond**

**Ontario**

## VBDS Geographic Regions

	<b>Northern Region</b>
	<b>Coastal Region</b>
	<b>Southern Region</b>

**30 full-time positions**

# **VBDS Mission Statement**

**To protect the health and well-being of Californians, and visitors to California, from arthropod- and vertebrate-transmitted diseases and injurious pests.**

# Activities & Responsibilities

- Surveillance and Control
- Disease Investigation
- Laboratory Support
- Expertise and Education
- Pesticide Use Certification



# Selected Vector-Borne Diseases

- **Flea-borne diseases:**

- Plague
- Murine typhus
- Bartonellosis (Cat scratch fever)



- **Mosquito-borne diseases:**

- West Nile virus
- St Louis encephalitis
- Zika, dengue, chikungunya
- Malaria



- **Rodent-borne disease:**

- Hantavirus



- **Tick-borne diseases:**

- Lyme disease
- Soft tick relapsing fever
- Tularemia
- Rocky Mountain spotted fever
- Pacific Coast tick
- Anaplasmosis
- Ehrlichiosis
- Babesiosis



- **Triatomine-borne disease:**

- Chagas disease



# Things to Consider

- Be suspicious of “summer flu”
- Many VBDs share “flu-like” symptoms that are easily dismissed or misdiagnosed
- COVID-19 infections can divert attention from vector-borne diseases

## Common Symptoms of Mosquito-Borne Disease



If you experience any of these symptoms...

Fever or chills



Head and body aches



Fatigue



Muscle weakness



Disorientation



Neck stiffness



Icons from flaticon.com

...after a mosquito bite, talk to a healthcare provider.

For more information, visit: [www.maine.gov/dhhs/vectorborne](http://www.maine.gov/dhhs/vectorborne)



# Things to Consider

- It's easy to miss vector-borne illnesses in differential diagnoses without adequate patient information
- Background on patient whereabouts, including recent activities, domestic, and international travel is crucial

**GOING TO THE AMERICAN TROPICS?**  
MOSQUITOES spread **DENGUE, CHIKUNGUNYA, ZIKA,**  
and other diseases



Mosquitoes bite day and night.  
Prevent mosquito bites:

- Use insect repellent
- Use air conditioning or window/door screens
- Wear long-sleeved shirts and long pants

**DON'T LET MOSQUITOES  
RUIN YOUR TRIP**

For more information, visit [www.cdc.gov/travel](http://www.cdc.gov/travel)



U.S. Department of  
Health and Human Services  
Centers for Disease  
Control and Prevention

# Things to Consider

- **Vector-borne infections can present with a wide range of clinical symptoms**
- **A percentage of mosquito-borne viral infections including WNV, dengue, chikungunya, and Zika may produce subclinical symptoms or be asymptomatic**

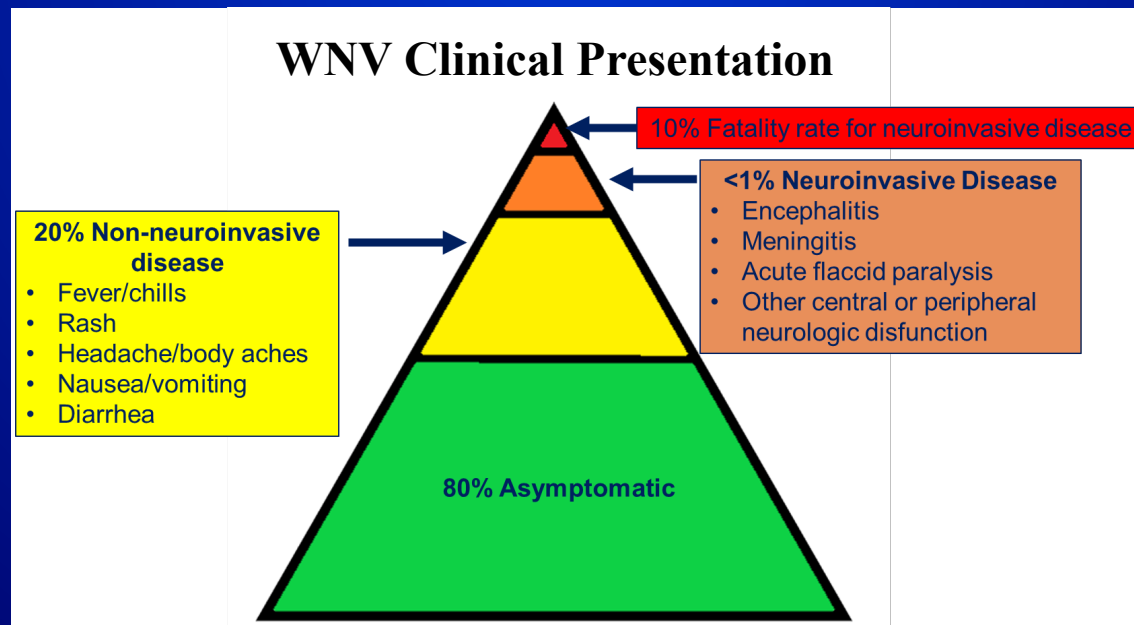

# Things to Consider

- Early diagnoses and treatment is critical to survival for some VBDs
- Especially hantavirus, RMSF, and plague

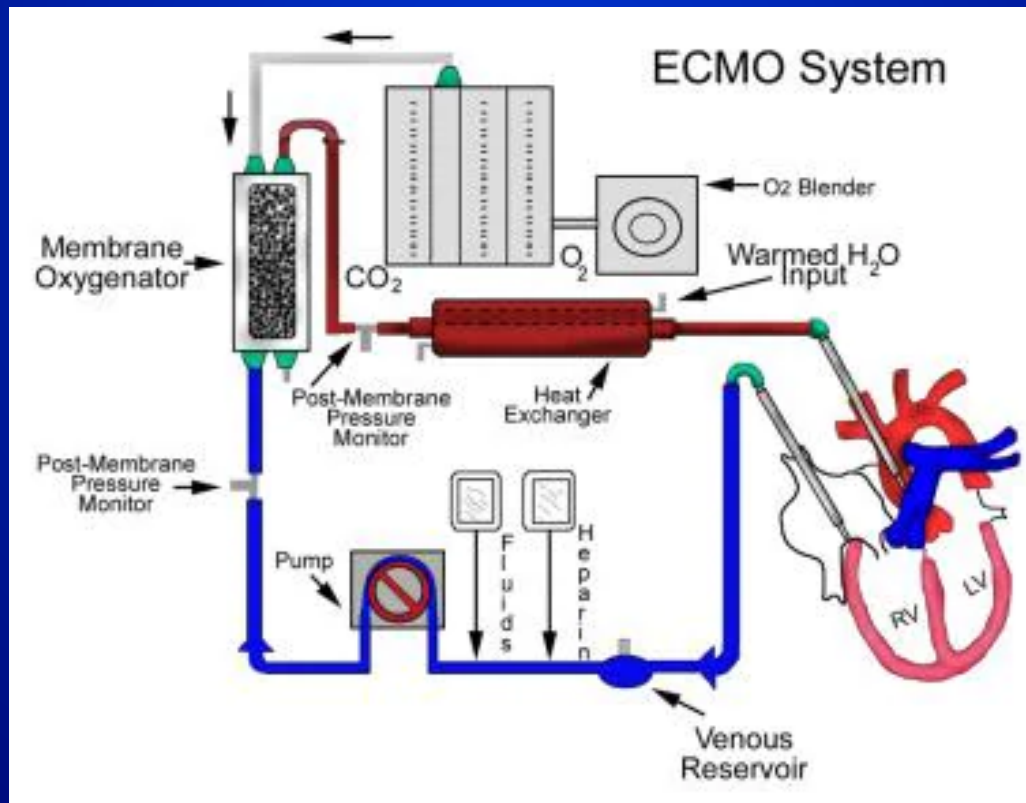

# Things to Consider

- **Sierra Nevada Range is California's hot spot for plague, hantavirus, and STRF infections**
- **Mono County has the highest per-capita incidence of hantavirus infections in California**



# Things to Consider

- **Hantavirus and STRF infections are nearly always a result of rodents living inside structures alongside humans**



# Things to Consider

- **Outdoor and feral cats can increase the risk of plague by hunting rodents and harboring rodent fleas**
- **Free-roaming dogs can increase risk of RMSF by sustaining brown dog ticks around homes**



# Things to Consider

- **Hantavirus and RMSF infections have been prevalent on tribal lands in the desert southwest**



# Things to Consider

- Mosquito-borne infections are most common at lower elevations in urban and suburban environments
- Dengue, Zika, and chikungunya are transmitted only by highly urban *Aedes* mosquitoes



# Things to Consider

- Presence of Norway rats, feral / outdoor cats, and urban wildlife (e.g. opossums, skunks, and raccoons) can increase the risk of flea-borne typhus in Los Angeles and Orange counties

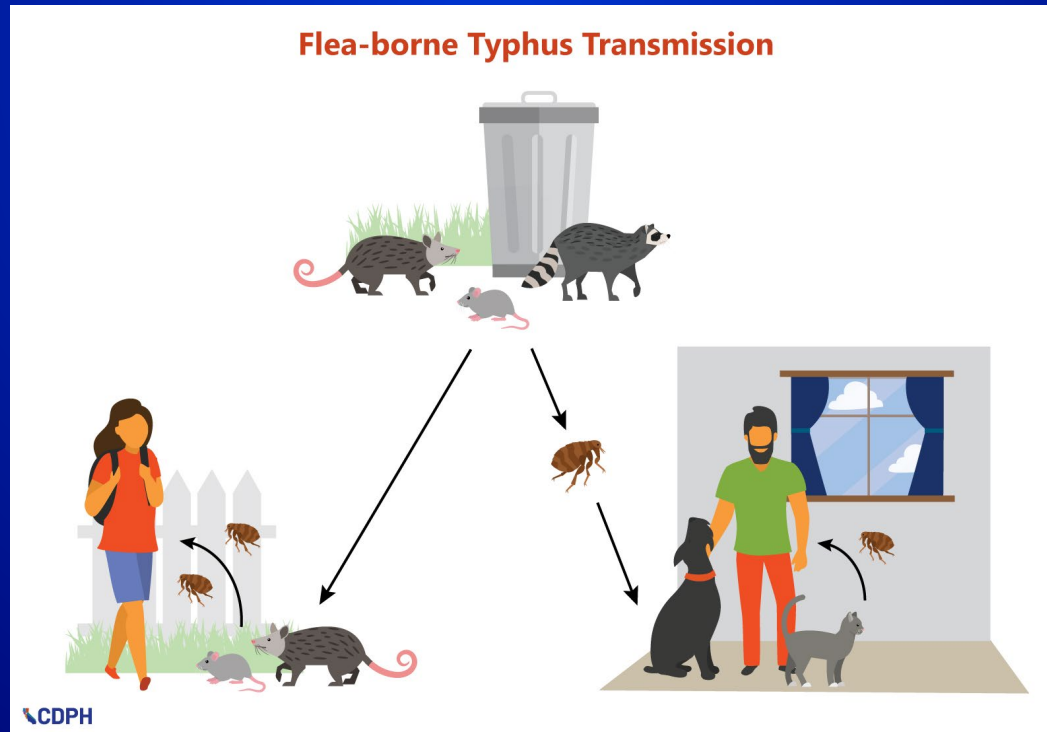

# Things to Consider

- Extensive resources are at your fingertips on the CDC and CDPH websites

## Preventing HANTAVIRUS PULMONARY SYNDROME in the Workplace



**What is hantavirus pulmonary syndrome (HPS)?**  
HPS is a severe and sometimes fatal respiratory disease. Sin Nombre virus (SNV) is the cause of HPS in the western United States. In California, **deer mice** are the primary carriers of SNV.

**How do people get HPS?**  
People get HPS from infected deer mice, which shed SNV in their urine, saliva, and droppings. Exposure can include:

- Breathing in the virus when dust or other small particles of mouse urine or droppings are stirred up into the air
- Touching the eyes, nose, or mouth after touching an object or surface that is contaminated with rodent urine or droppings



**How can I prevent HPS?**  
You can help prevent hantavirus infection by keeping wild rodents out of your workplace.

**SEAL** holes and gaps around doors, windows, and pipes to keep mice out.



**TRAP** mice with snap traps (*do not use sticky traps*) – place traps next to a wall and routinely check to remove rodents that have been caught.

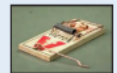

**CLEAN** your workplace:

- Reduce rodent food sources by storing food in tightly-sealed containers
- Remove materials that mice can use to make nests (including boxes, newspapers, and woodpiles)
- Disinfect areas where dead mice, droppings, or nests are found

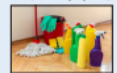

**Clean-up Tips:**

1. Before starting any clean-up, air out the work space for at least 30 minutes.
2. **DO NOT** sweep or vacuum areas where mouse droppings, urine, or nests may be found.
3. Use only wet-cleaning methods, such as a mop or sponge, to reduce the chance of stirring up (aerosolizing) the virus.
4. Wear latex or rubber gloves during cleaning, and wash hands with soap and warm water when finished.
5. Spray contaminated areas with a 10% bleach solution, or use a disinfectant that kills viruses that is diluted according to the label instructions. Allow the solution to sit for 5 minutes or according to label instructions before cleaning up.

More information: <https://bit.ly/HantavirusCDPH> or <https://www.cdc.gov/hantavirus/>  
To order copies of this poster, contact the Vector-Borne Disease Section: VBDScdph.ca.gov  
The California Department of Public Health is an equal opportunity employer.



## FACTS ABOUT PLAGUE IN CALIFORNIA

You can minimize your exposure to plague by carefully following the precautions listed in this pamphlet.

California Department of Public Health  
Vector-Borne Disease Section  
(916) 552-9730  
March 2016

## Common Ticks in California



Ticks are often found in areas with grass, shrubs, logs, large rocks, or fallen leaves. **Brown dog ticks can be found in or around the home and in dog kennels.**



Females	Males	
		<b>Western blacklegged tick</b> <i>Ixodes pacificus</i>
		<b>Pacific Coast tick</b> <i>Dermacentor occidentalis</i>
		<b>American dog tick</b> <i>Dermacentor variabilis</i>
		<b>Brown dog tick</b> <i>Rhipicephalus sanguineus</i>

**Actual size:** 

**Check for ticks!**

Western blacklegged tick







**Female Male Nymph Blood-fed adult**

# PLAGUE (*YERSINIA PESTIS*)

- **Bacteria**
  - 50-60% fatality rate in humans if not treated
- Transmitted by the bite of an infected flea
- Typically found in enzootic cycle in the USA
- Epizootic cycles occur when there are increased periods of disease

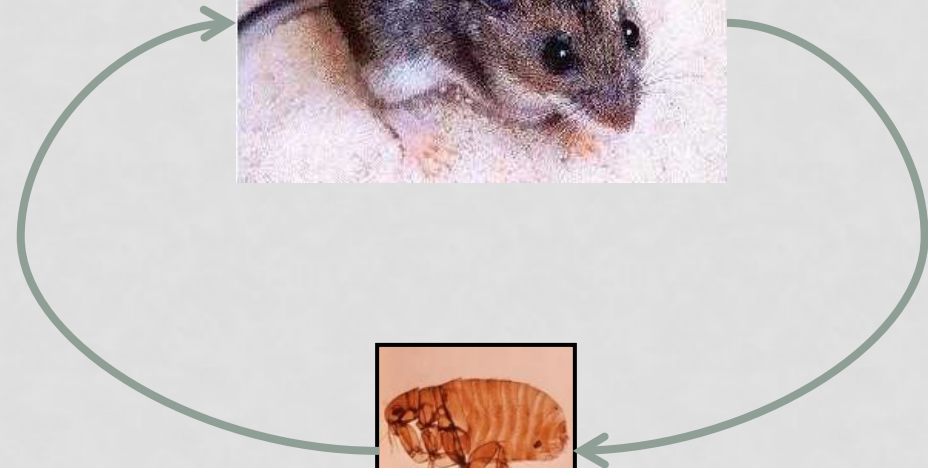
Enzootic Cycle



# RODENT RESERVOIRS

- **Resistant reservoirs:**  
deer mice, voles, chipmunks



**Enzootic transmission**



- **Susceptible/amplifying reservoirs:**  
ground squirrels, chipmunks

**Epizootic transmission**

## Reported cases of human plague--United States, 1970-2012

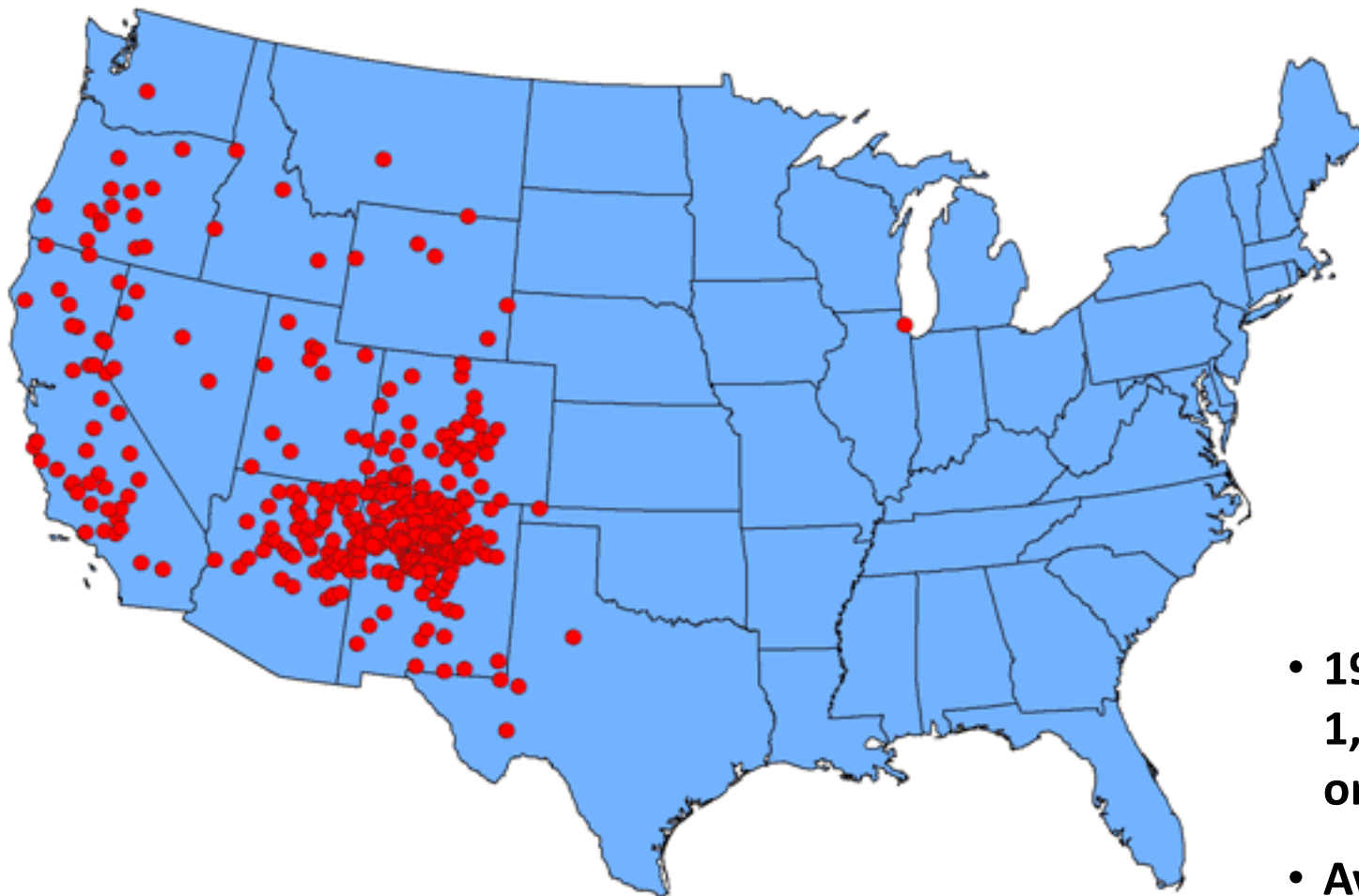

1 dot placed in county of exposure for each plague case

- **1900-2012:**  
1,006 confirmed  
or probable cases
- **Avg 7 cases/year**  
(Range 1-17)
- **CA 1926-2006:**  
62 human cases

# PLAGUE IN CALIFORNIA RODENTS

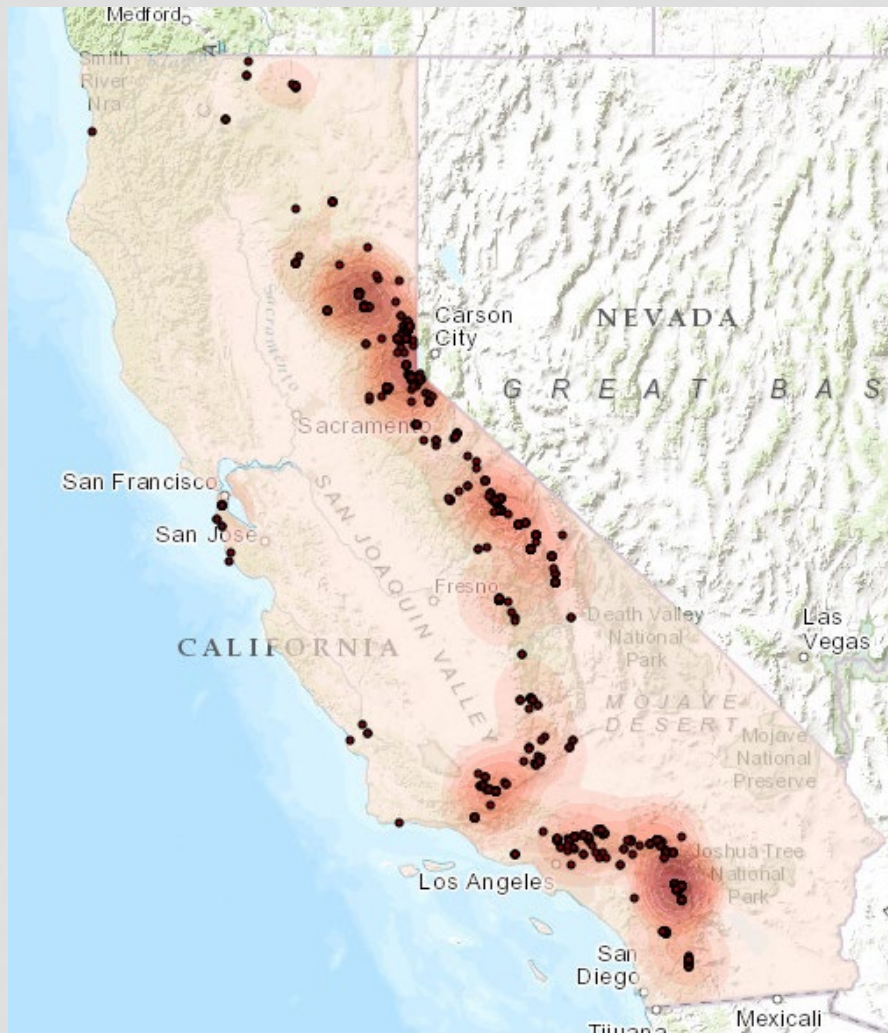

## Legend

1984 - 2013, Locations of  
Plague-positive Rodents



1984 - 2013, Density of Plague-  
positive Rodents

Class



# California Ground Squirrel (*Otospermophilus beecheyi*)

- Species commonly associated with human plague cases
- Widely distributed & locally abundant
- Sylvatic & peridomestic
- Fleas abundant on animals & in burrows
- Fleas from these rodents are known plague vectors and will bite humans



California Ground Squirrel  
*Otospermophilus beecheyi*  
M072

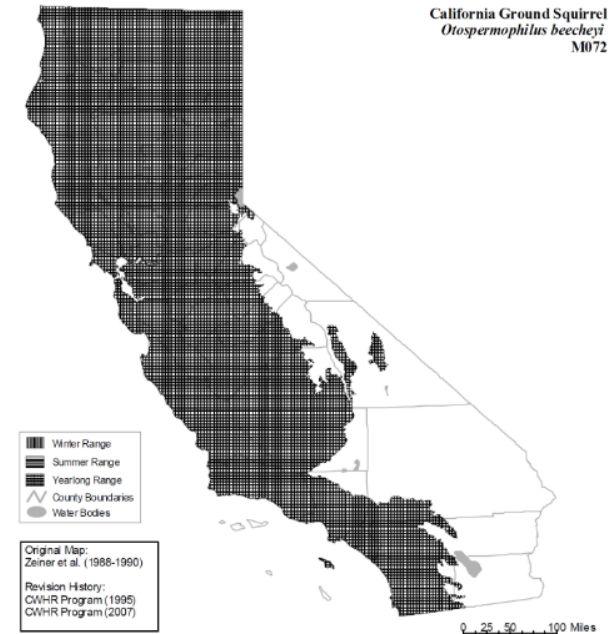

# MODES OF TRANSMISSION

- Flea bite (most common)
- Direct contact with infected rodents or other animals (e.g. skinning animal)
- Inhalation of aerosols from close contact with felines or humans with plague pneumonia



# HUMAN SYMPTOMS OF PLAGUE

- **Bubonic**
  - Swollen, tender lymph nodes (buboes) in neck, armpit or groin
  - Most common form in US (80% cases)
- **Septicemic**
  - Secondary blood infection
- **Pneumonic**
  - Primary or secondary lung infection (pneumonia)

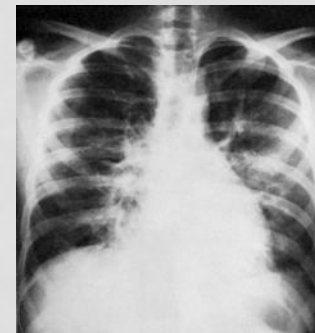

# **FACTORS THAT INCREASE RISK OF HUMAN EXPOSURE**

- **History of plague transmission in the region**
- **High rodent populations (e.g., ground squirrels & chipmunks)**
- **High flea index**
- **High human-rodent contact (e.g., campgrounds)**
- **Evidence of rodent die off / fleas at burrow entrances**
- **Outdoor cats with hunting tendencies**

# Hantaviruses are found Worldwide

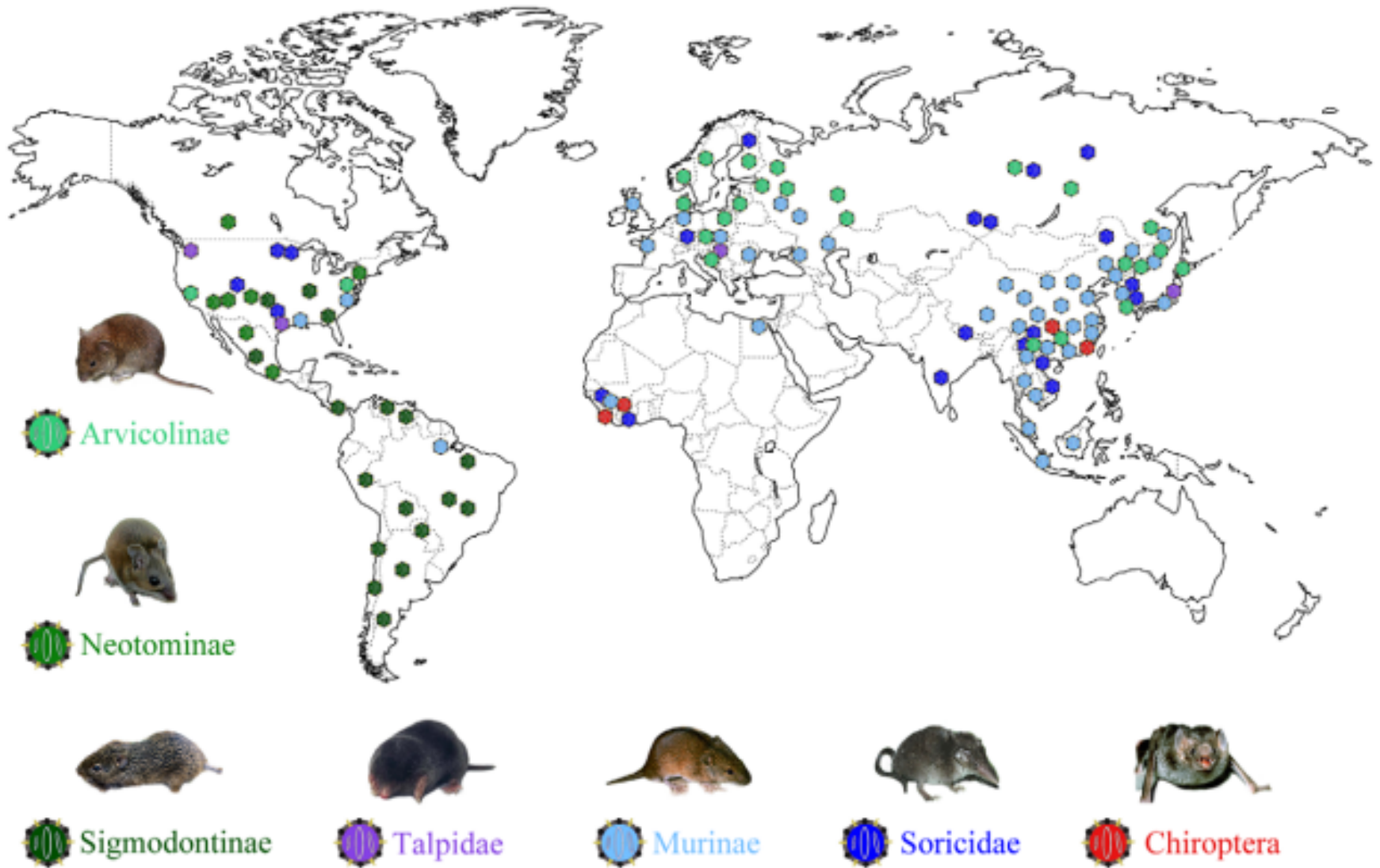

**Figure 3. A map of the world illustrating the location of known hantaviruses by host group and associated mammalian hosts.**  
doi:10.1371/journal.ppat.1003159.g003

# Hantavirus Pulmonary Syndrome in North America

- 1993 Four Corners outbreak
  - Unusual cluster of deaths
  - 23 cases of severe respiratory illness
  - Case fatality > 80%
- Etiology
  - “Sin Nombre” virus (SNV)
  - Deer mice (*Peromyscus maniculatus*) identified as reservoir and vector



# Deer Mice and Hantavirus

- **Abundant throughout California**
- **Readily enter homes and other buildings for food and shelter**
- **Statewide average ~12-14% seropositive**
- **Do not show signs of illness**



# Transmission of Hantaviruses

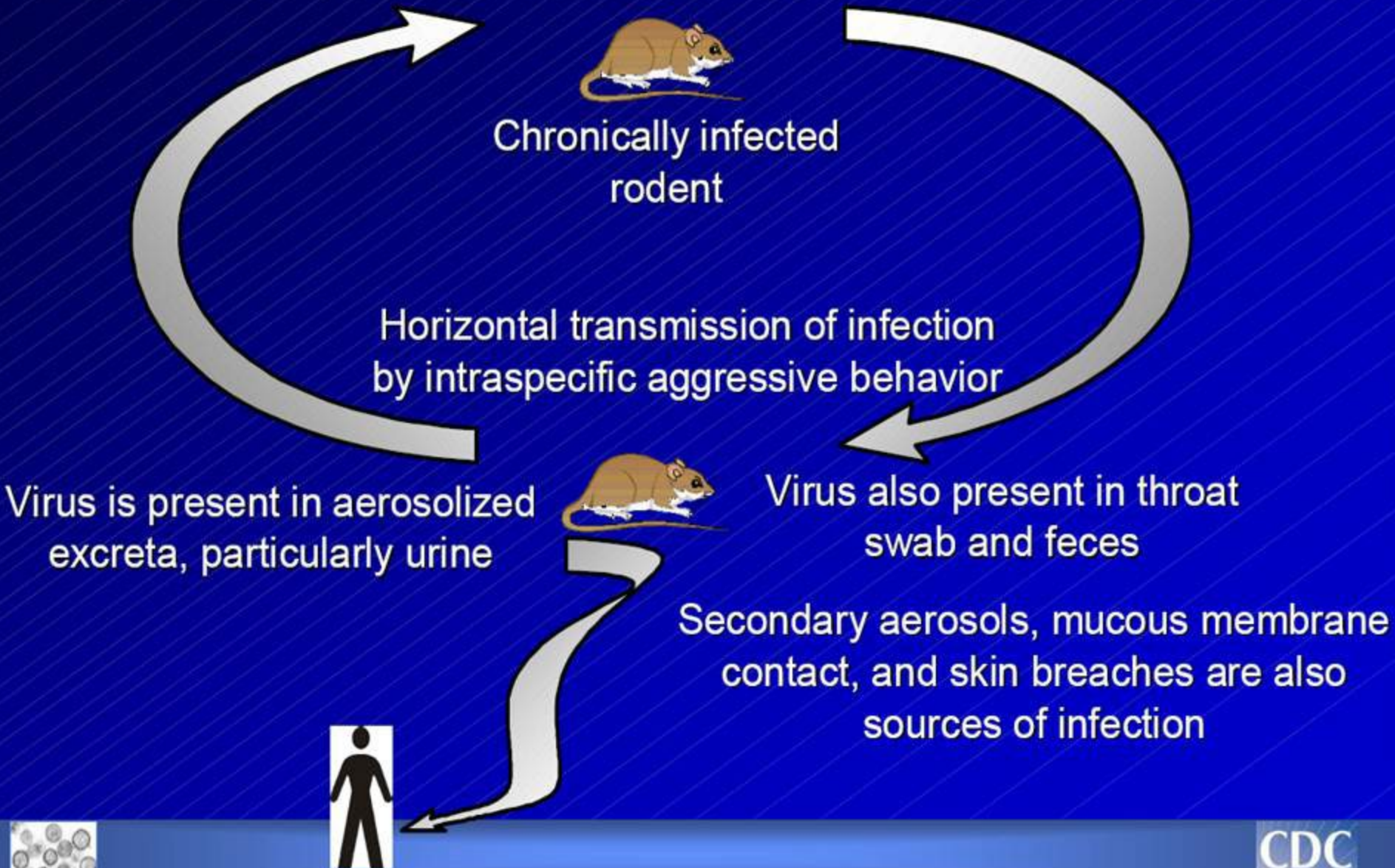

# Map of U.S. Cumulative Cases of Hantavirus by State through 2022

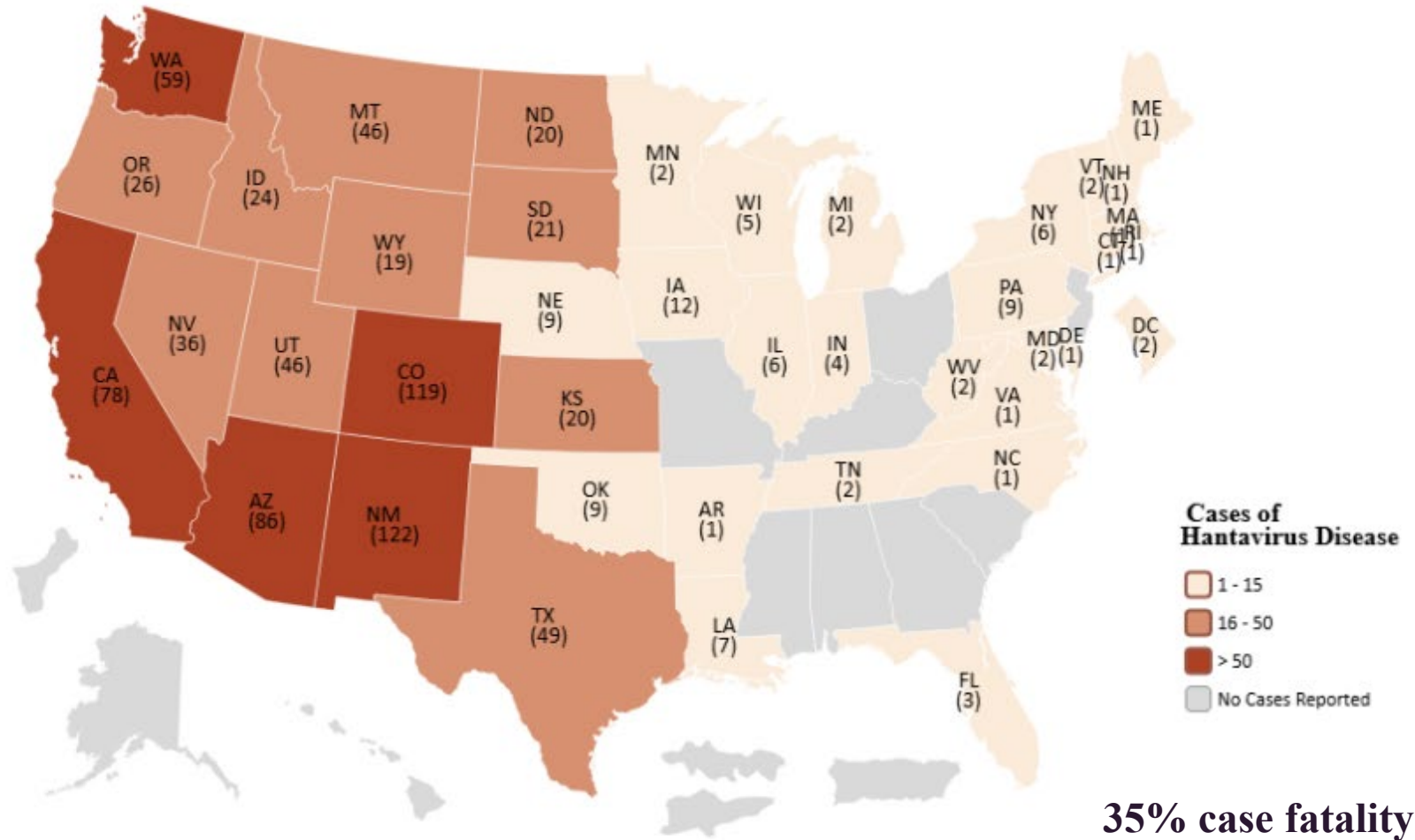

All cases were confirmed between 1993-2022 and met the NNDSS case definition applicable at the time of reporting. Included in the sum total are 31 historical cases that occurred prior to 1993, but were confirmed retrospectively. Five cases had presumed exposure outside the United States.

# Hantavirus Infections in California Residents 1980-2025

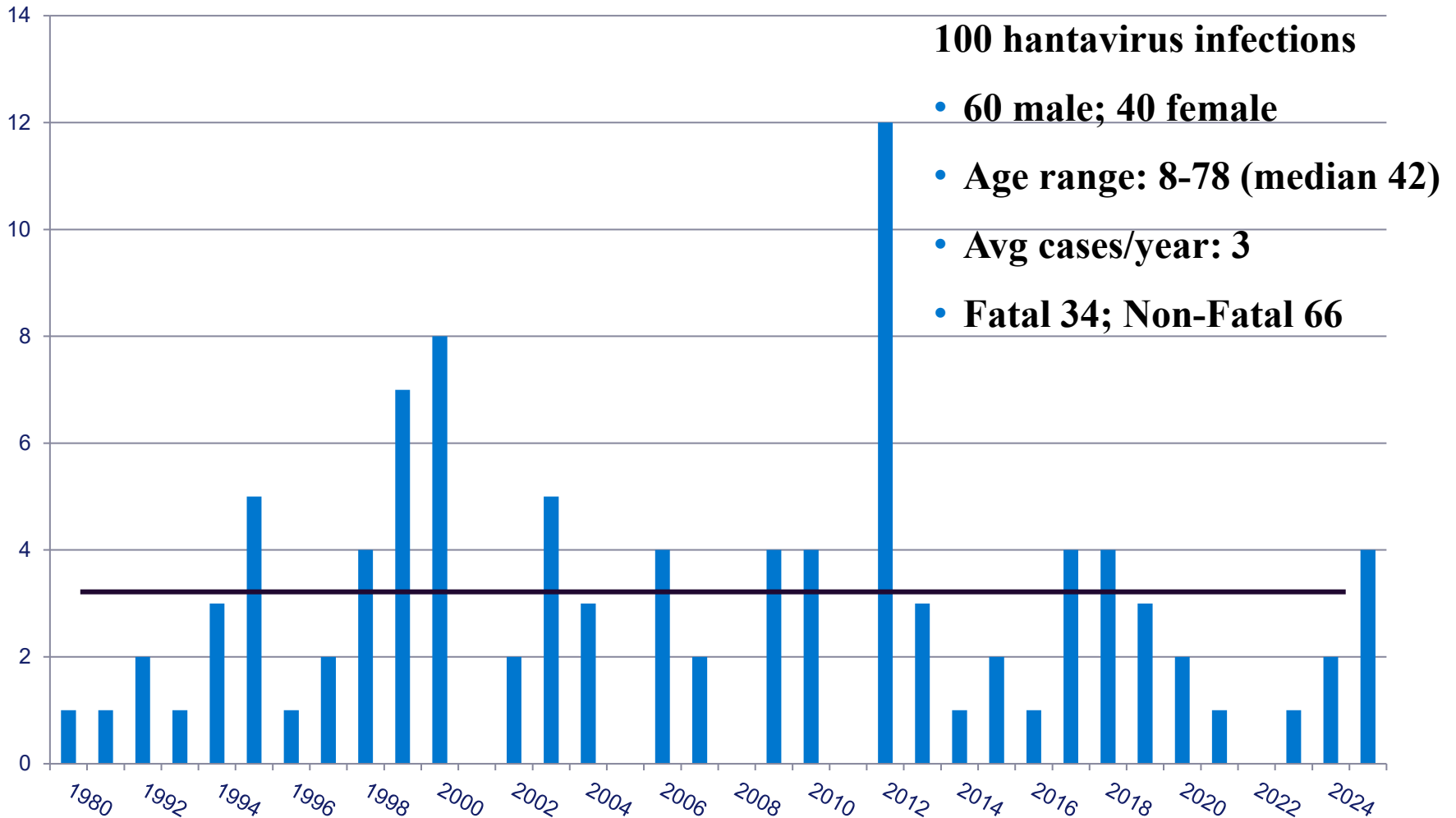

# County of Exposure for Reported Hantavirus Infections in California Residents, 1980 – 2024 \*

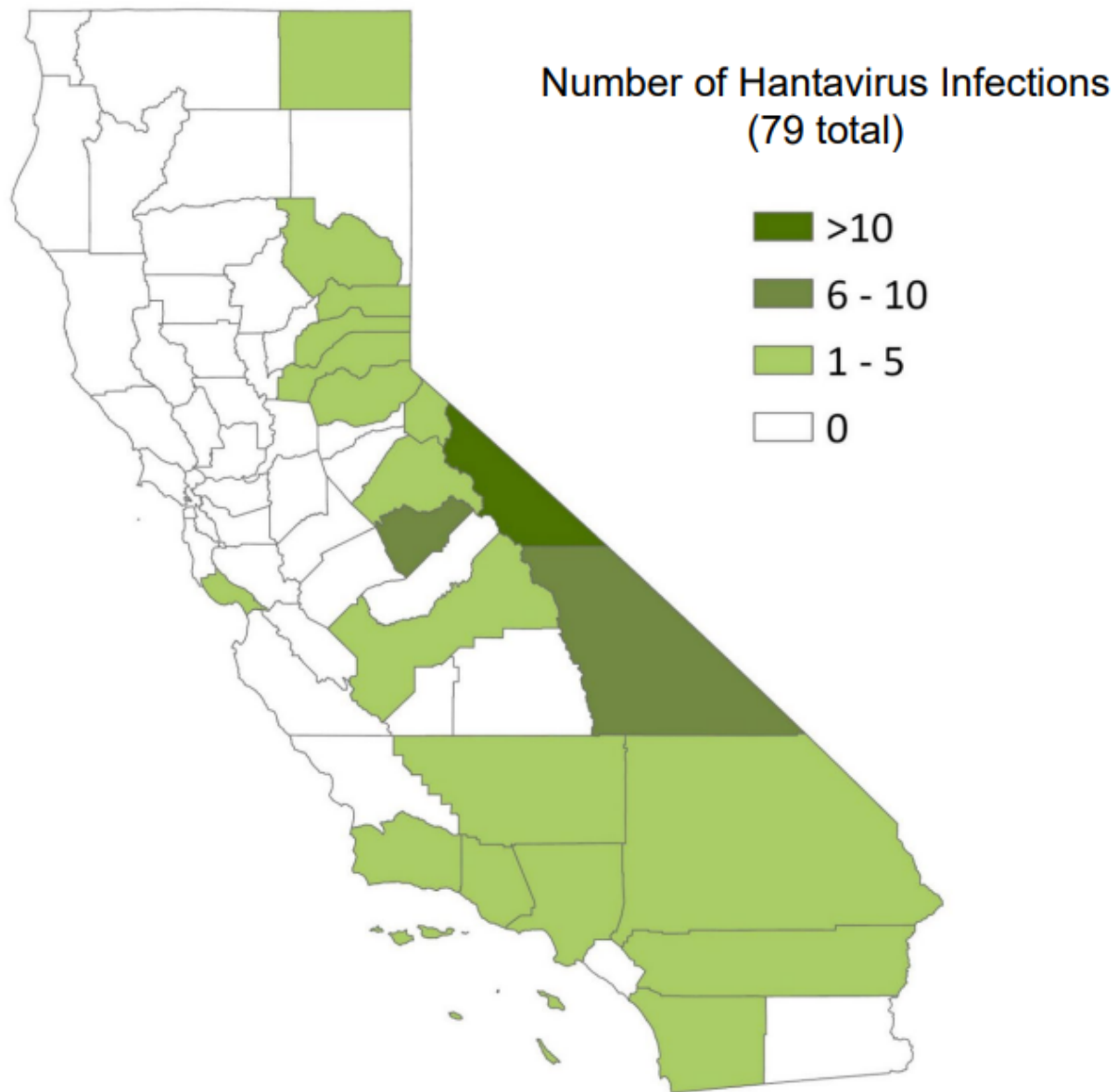

# Exposure Circumstances in CA Residents 1980 - 2025

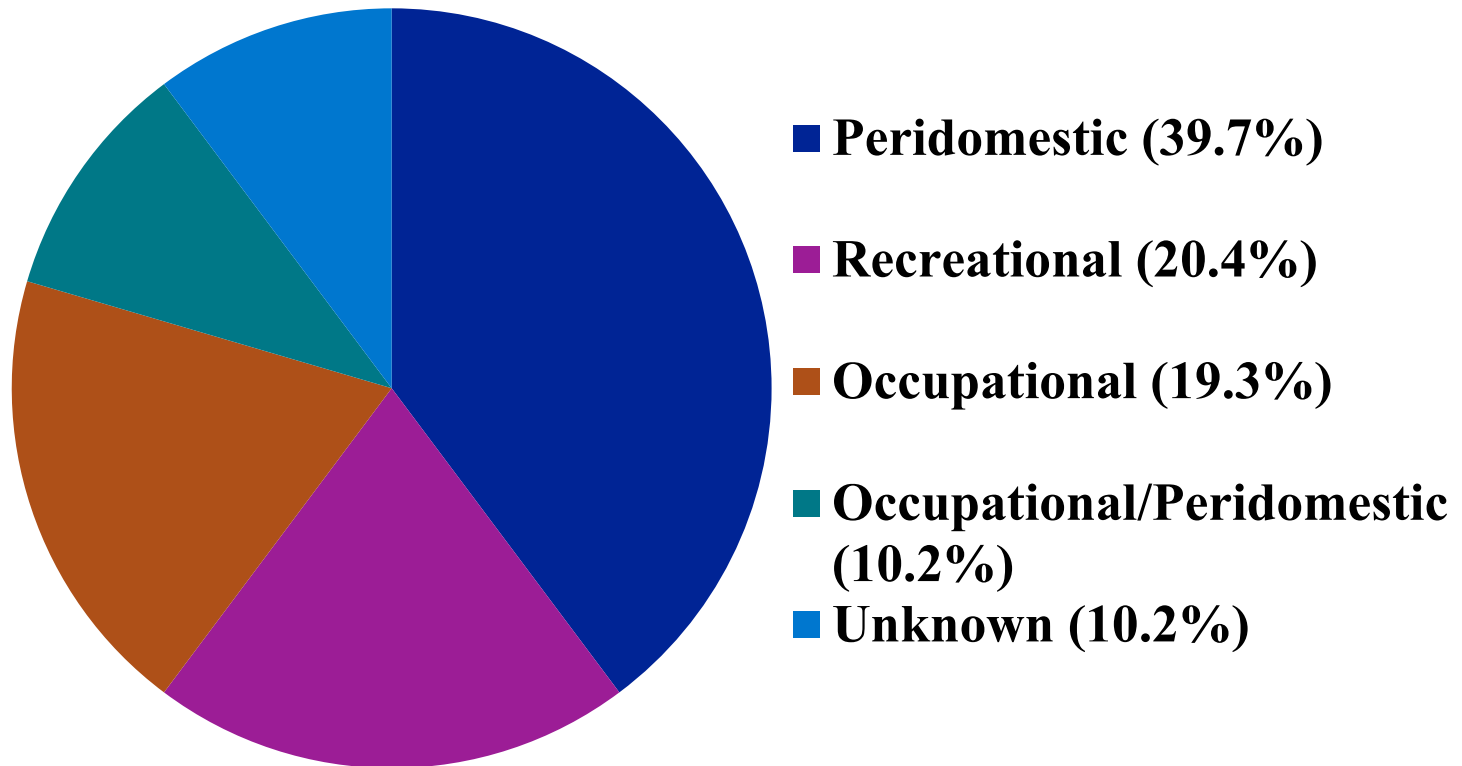

# Risk of Contracting HPS

- **Associated with increased numbers of deer mice in / around residence / structure**
- **Contact with rodent excrement puts one at greatest risk**
  - **Cleaning rodent-infested structures, especially those closed for a while (e.g., over winter)**
  - **Living / working in rodent-infested structures**
- **Most outdoor locations and activities considered low risk**
- **SNV transmission not documented person-to-person**



# Hantavirus Infection

- **Incubation: 2-4 weeks (range 9-49 days)**
- **Prodrome Phase: 3 – 6 days**
  - **Clinical symptoms include headache, fever, muscle and body aches, chills, dry cough, nausea, vomiting, diarrhea**
- **Pulmonary Phase: Abrupt onset of respiratory distress, 4 – 24 hours**
  - **Pulmonary edema – fluid accumulation in the lungs**
  - **Hypoxia – tissues deprived of oxygen**
  - **Severe hypotension – low blood pressure**

# Acute Respiratory Distress Syndrome (ARDS)

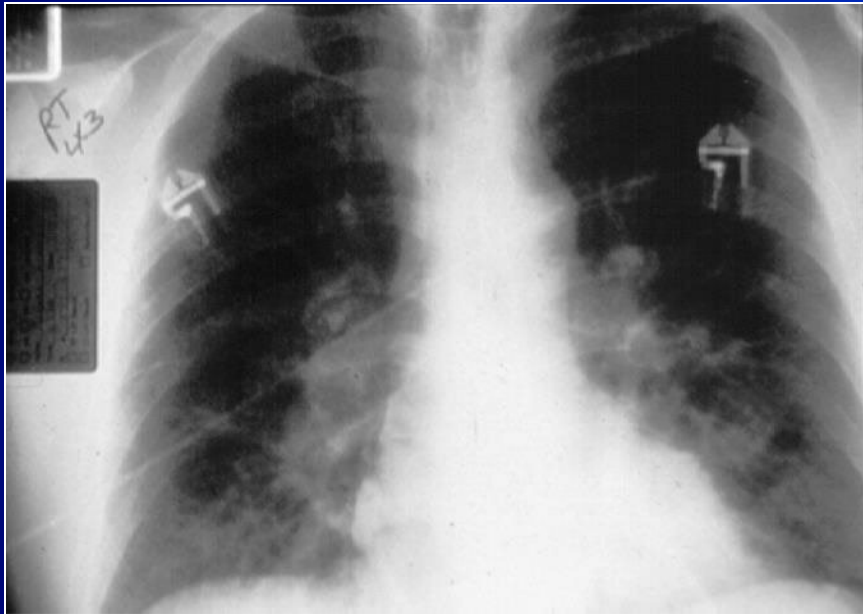

**3 days post-onset**

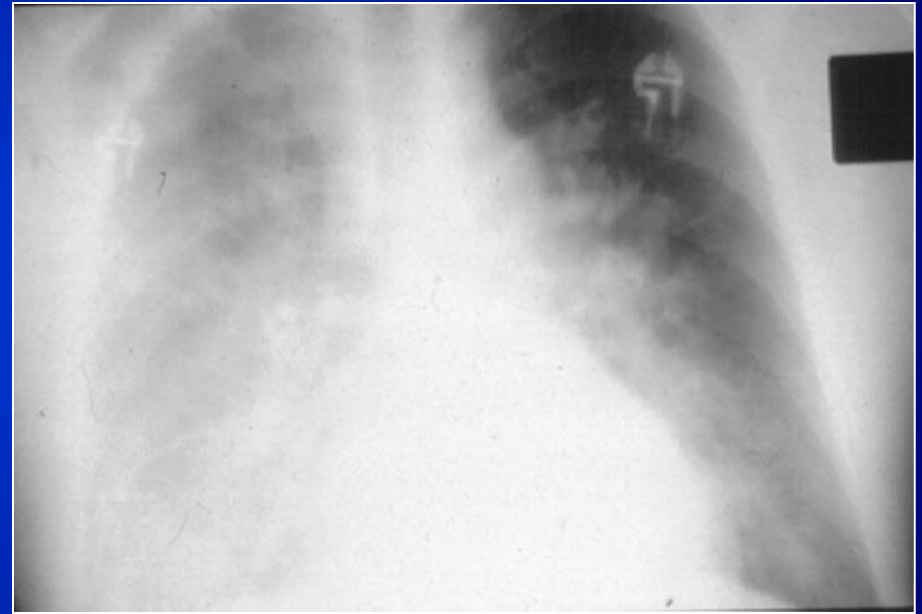

**6 hours later**

# Treatment of Hantavirus

- **No effective antiviral agent currently available**
- **Treatment is largely supportive - need to be hospitalized quickly. Death occurs in roughly 30-40% of cases**
- **Extracorporeal Membrane Oxygenation (ECMO) as a last resort**

# Risk Reduction / Personal Protection

- **Education**
  - Presentations, information brochures
- **Exclude / reduce rodent harborage in structures**
- **Destruction of virus**
  - Open structures to light and air prior to entering
  - Disinfect with bleach, Lysol, or household disinfectant
- **Prevent inhalation of virus**
  - Wear mask when cleaning (N-95 or better)
  - Mop rather than sweep / vacuum



# Tick-Borne Diseases

- **Present in California**
  - Lyme disease, RMSF, PCTF, STRE, Anaplasmosis
- **Transmitted by bite of infected tick**
  - Vector tick varies for each disease
  - “Hard” and “soft” ticks
- **Distribution throughout California**
  - Patchy distribution of vectors



# Typical Hard Tick “Three Host” Life Cycle

**Note:** The life cycle of a 3-host tick may take 1-2 years depending on whether or not the tick can find a suitable host between life stages.

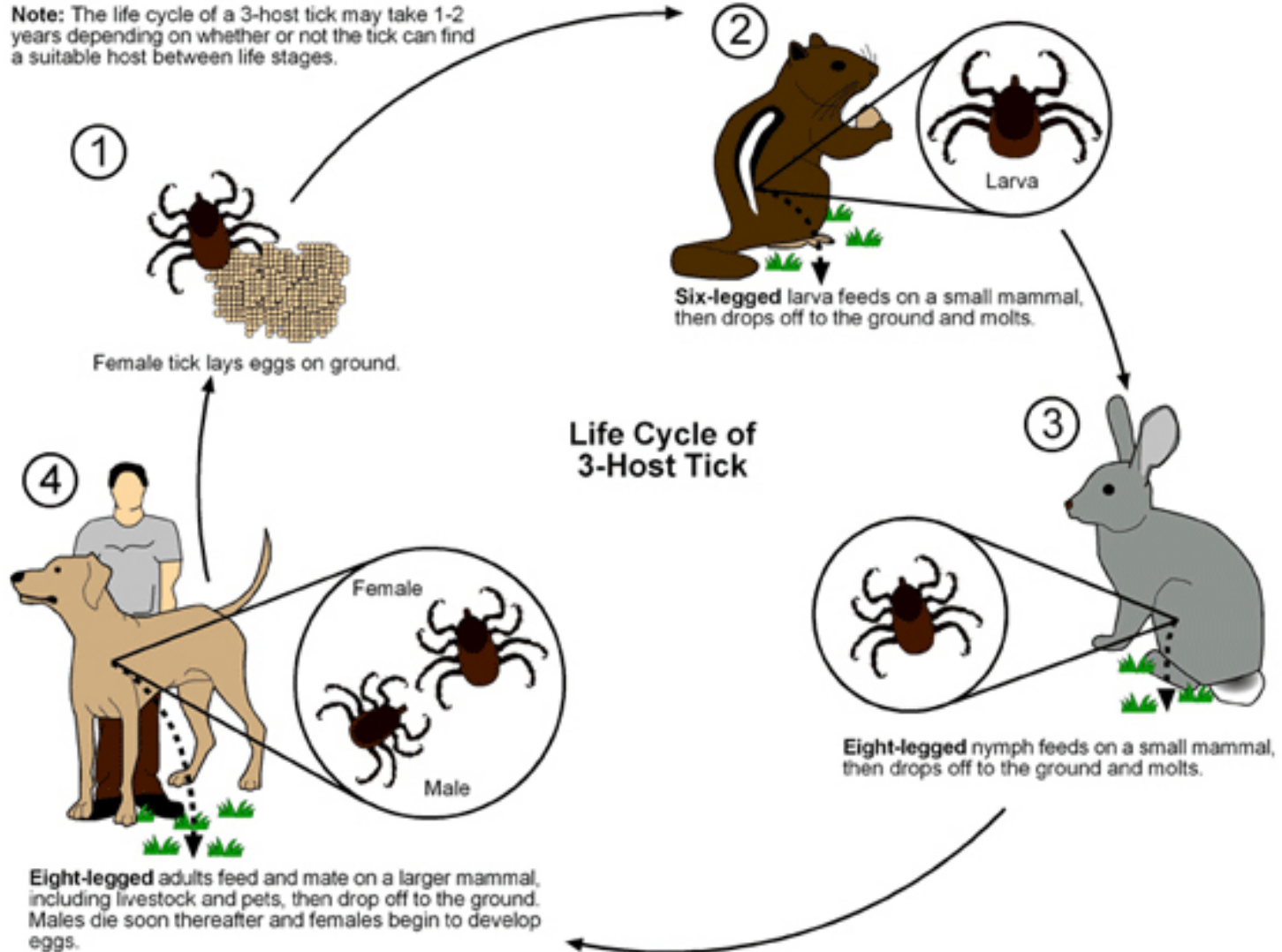

# Soft Tick Life Cycle

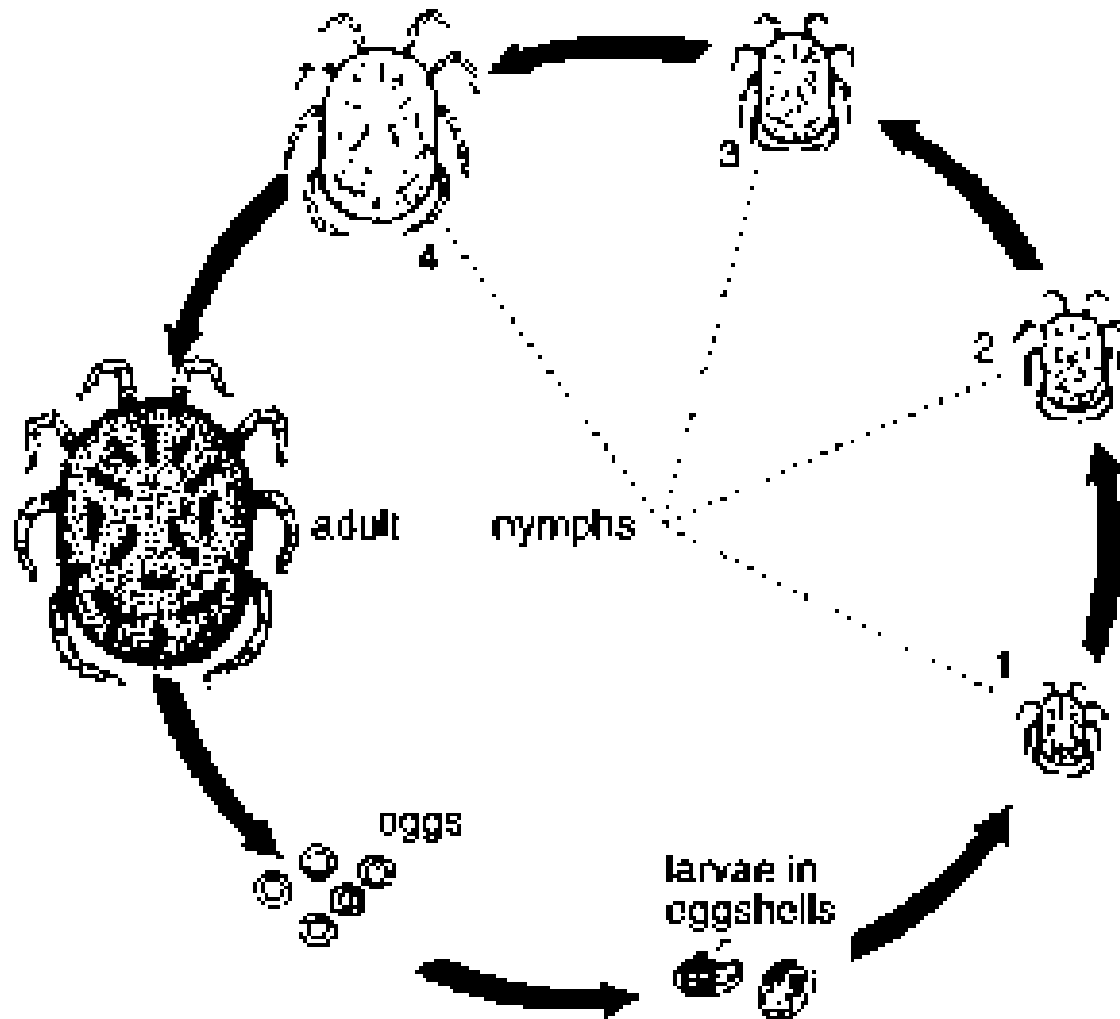

# Personal Protection Measures Against Hard Ticks

- **Avoid contact with ticks**
- **Wear protective clothing**
- **Apply tick repellent**
  - **DEET is most effective**
- **Apply permethrin products to clothes & shoes**
- **Daily tick check / removal**



# Proper Hard Tick Removal

1. Grasp tick with tweezers close to skin. Be careful not to squeeze the tick's abdomen
2. Pull the tick straight out, slowly and firmly. Do not jerk or twist the tick
3. Wash the area thoroughly
4. If possible, save the tick

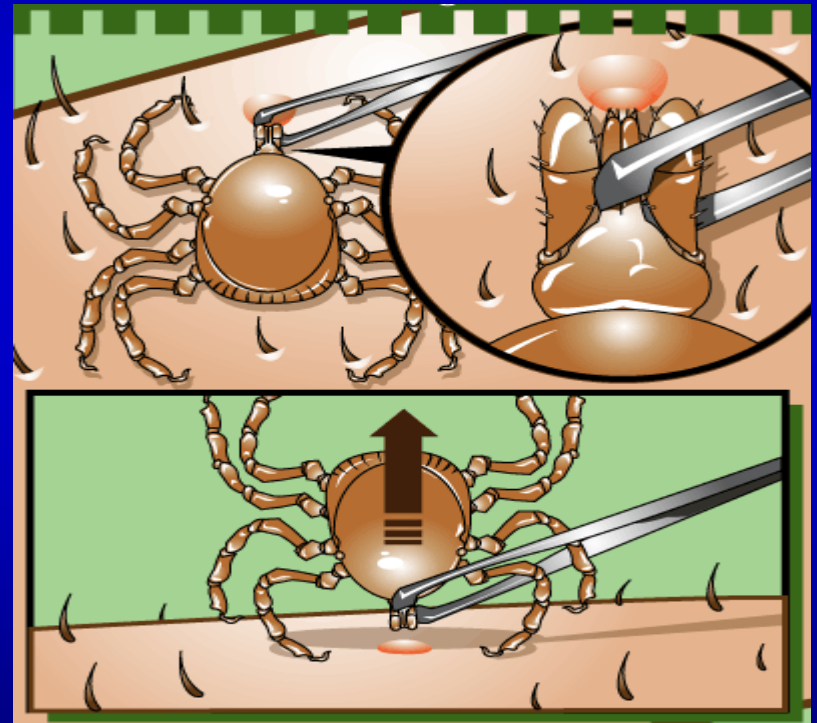

# Rocky Mountain Spotted Fever

- **First described in the U.S. in 1890s**
- **About 2500 cases per year in the USA**
- **Intracellular bacteria (*Rickettsia rickettsii*) attacks endothelial cells and causes widespread vascular damage**
- **Sylvatic and urban tick vectors**
- **All stages of ticks can transmit the organism**



# Tick Vectors of RMSF

*Rhipicephalus sanguineus*  
Brown dog tick



*Dermacentor variabilis*  
American dog tick



*Dermacentor andersoni*  
Rocky Mountain wood tick



# Tick Biology

- **Most ticks have moisture and temperature requirements**
  - **Vulnerable to desiccation, like high humidity, low tolerance for temperature extremes**
- **The brown dog tick is different**
  - **Thrives in hot climates**
  - **Requires less water than other ticks**
  - **Vulnerable to colder temperature**
  - **Can live indoors as long as there are dogs**
  - **Can crawl up and hide in walls, stucco, cracks, crevices, and carpet**

# Brown Dog Tick (*Rhipicephalus sanguineus*) Life Cycle



Source: Parasit Vectors. 2010; 3: 2

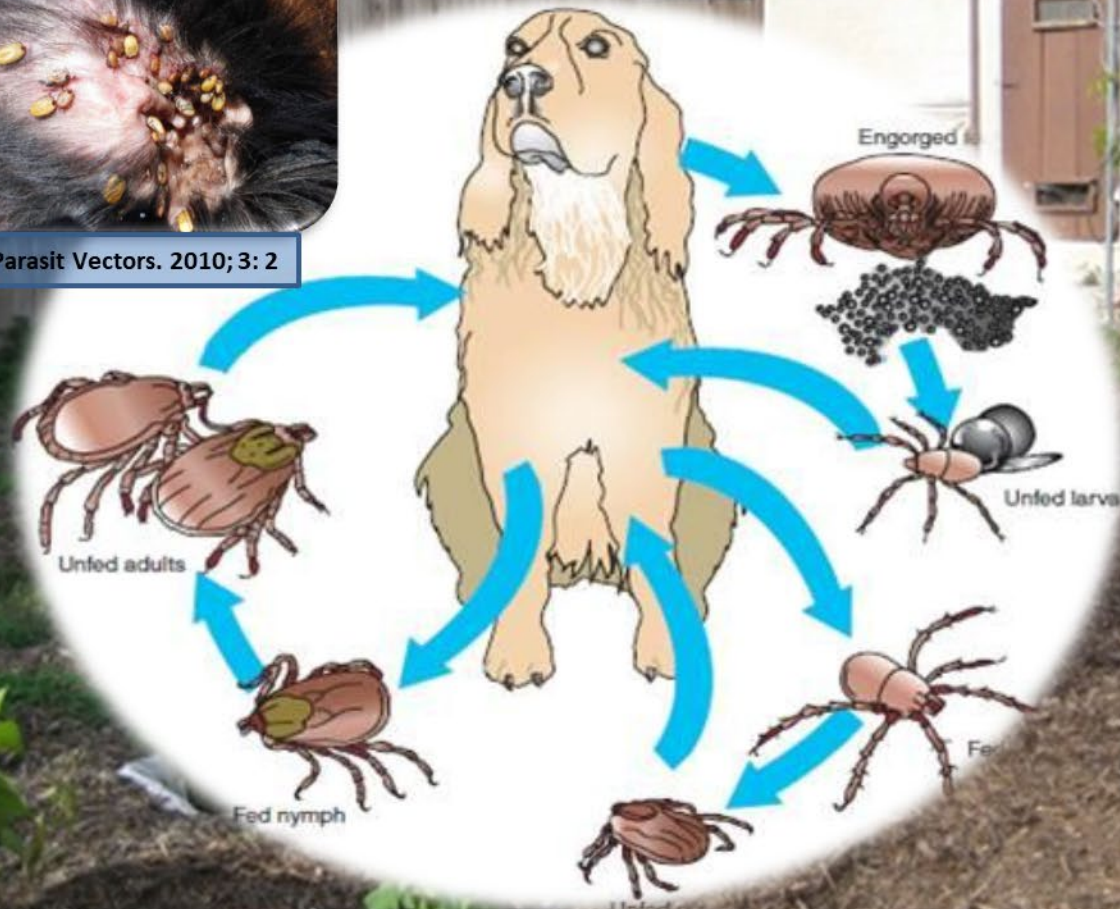

Source: University of Florida

# **RMSF – Clinical Manifestation**

- **Early (first 4 days): fever, headache, myalgia, abdominal pain, light rash**
  - **Thrombocytopenia, hyponatremia, elevated liver enzymes may occur**
- **Late (day 5 or later): definitive petechial rash, altered mental status, seizures, cough, hypotension, arrhythmias, dyspnea, severe abdominal pain**
- **Many do not recall a tick bite**

# **RMSF – The Rash**

- **Not consistent enough in presentation / timing for treatment decisions (only seen in 70-80%)**
- **Generally not apparent until day 2-5 of symptoms**
- **May begin on ankles, wrists, and forearms and spreads to trunk**
- **Petechial rash is a late finding, on or after day 6**



# Deaths Attributable to RMSF

- **Historical case fatality rate 20-80% in untreated cases**
- **ARDS, DIC, and organ failure may begin around day 5 in severe cases**
- **Infection kills otherwise healthy adults and kids**
- **Median time from symptom onset to death is 8 days**

# Risk Factors for Death

- **Lack of recognized tick bite**
- **Missed or late diagnosis**
  - **Presentation outside of summer tick season**
  - **Late onset of rash**
  - **Symptoms mimic more common illnesses**
- **Wrong antibiotic treatment:**
  - **e.g. broad-spectrum antibiotics are ineffective**

# **RMSF – Intervention**

- **Treat EVERY SUSPECT CASE with doxycycline**
- **Community awareness / education is critical**
- **Canine-focused**
  - **Use long-acting acaracides (e.g. collars)**
  - **Limit free-roaming**
  - **Spay/neuter**
- **Environment**
  - **Remove outdoor clutter that can harbor / shelter ticks**
  - **Apply acaracides to knock down large tick infestations**
  - **Seals cracks and crevices on homes**

# American Trypanosomiasis (Chagas Disease)

- Protozoan parasite *Trypanosoma cruzi*
- Infects >100 species of mammals
- Vectored by >100 species of Triatomid bugs via parasite-contaminated feces entering skin lesions, eyes, or mouth
- Other modes include contaminated food, blood transfusion, congenital, and organ transplant
- Estimated 5.7 million people infected in Latin America, with 30,000 new cases annually



# Trypanosoma cruzi

## Triatomine Bug Stages

## Mammalian Stages

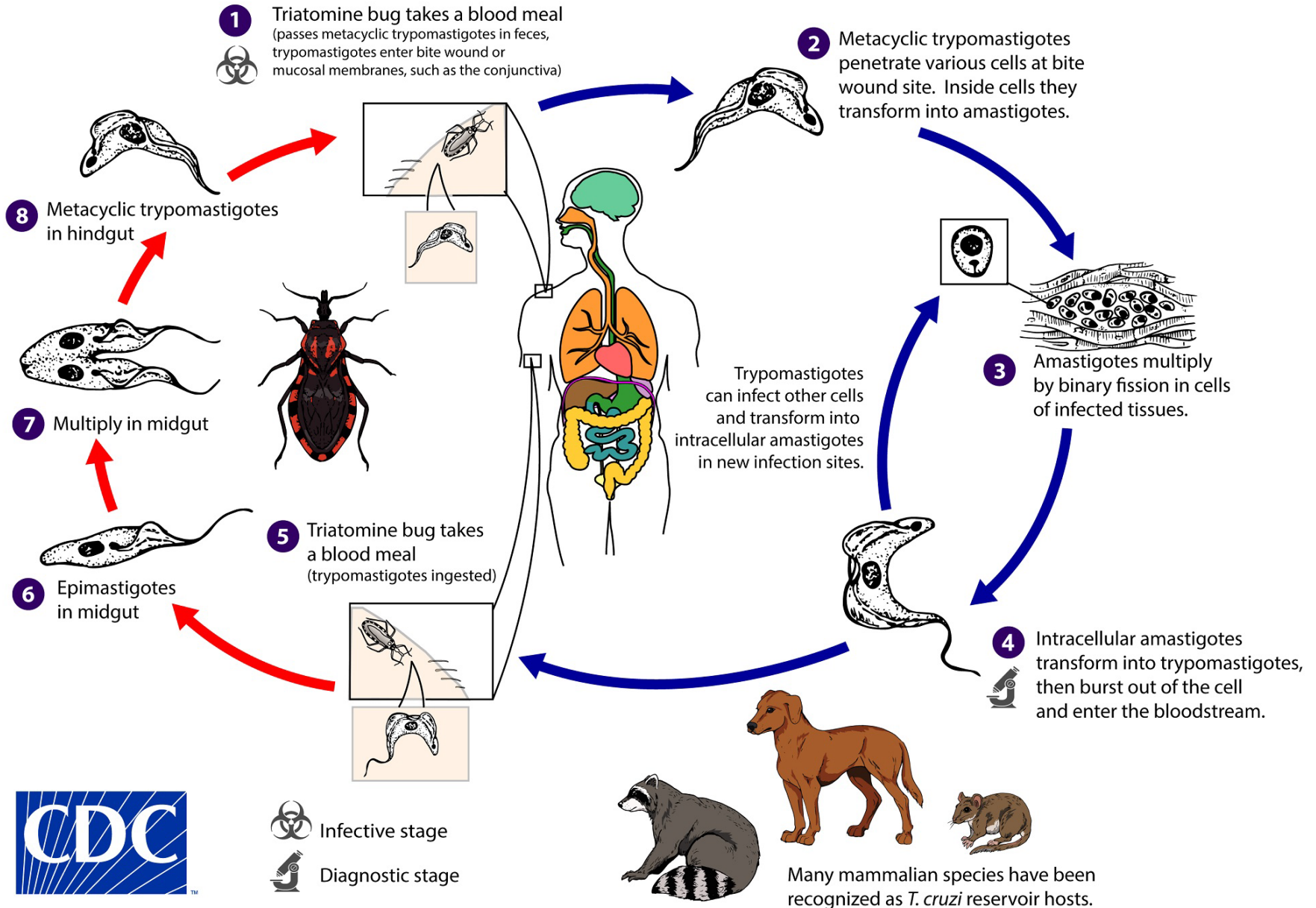

# *T. cruzi* transmission in California

## Main reservoir host

Dusky-footed woodrat  
*Neotoma fuscipes*



Infected via eating  
infected bugs

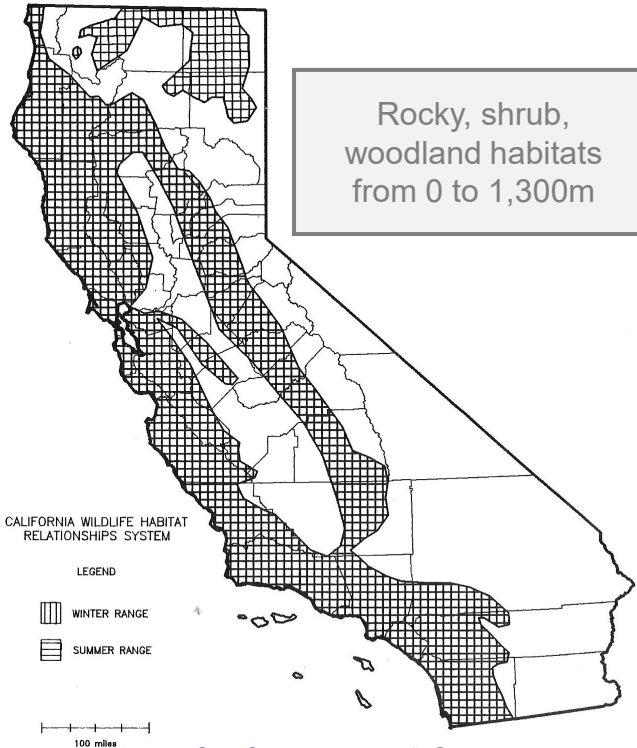

## Main vector

Western conenose bug  
*Triatoma protracta*



Distribution mirrors  
woodrat hosts

# Western Cone-Nosed Bug

*Triatoma protracta*



- **Locally abundant in undeveloped areas**
- **Long lived with life cycle taking over one year**
- **Adult flights occur primarily during the summer season, on warm evenings (65-84°F; 1<sup>st</sup> hour after dark). Attracted to lights**
- **May occasionally produce offspring inside homes, but does not colonize**
- ***T. cruzi* infected bugs found throughout CA – percentages vary**

# Chagas Disease in Humans

## Acute Phase

- **High blood parasitemia for ~ 2 months**
- **Often asymptomatic or mild**
- **Symptomatic cases vary**



## Chronic Phase

- **Parasites hide in target tissues, especially muscles of cardiac and digestive systems**
- **Lifelong infection with different clinical forms (asymptomatic, cardiac, digestive, mixed)**
- **Can be fatal**

# Local Transmission is Possible, but Very Rare

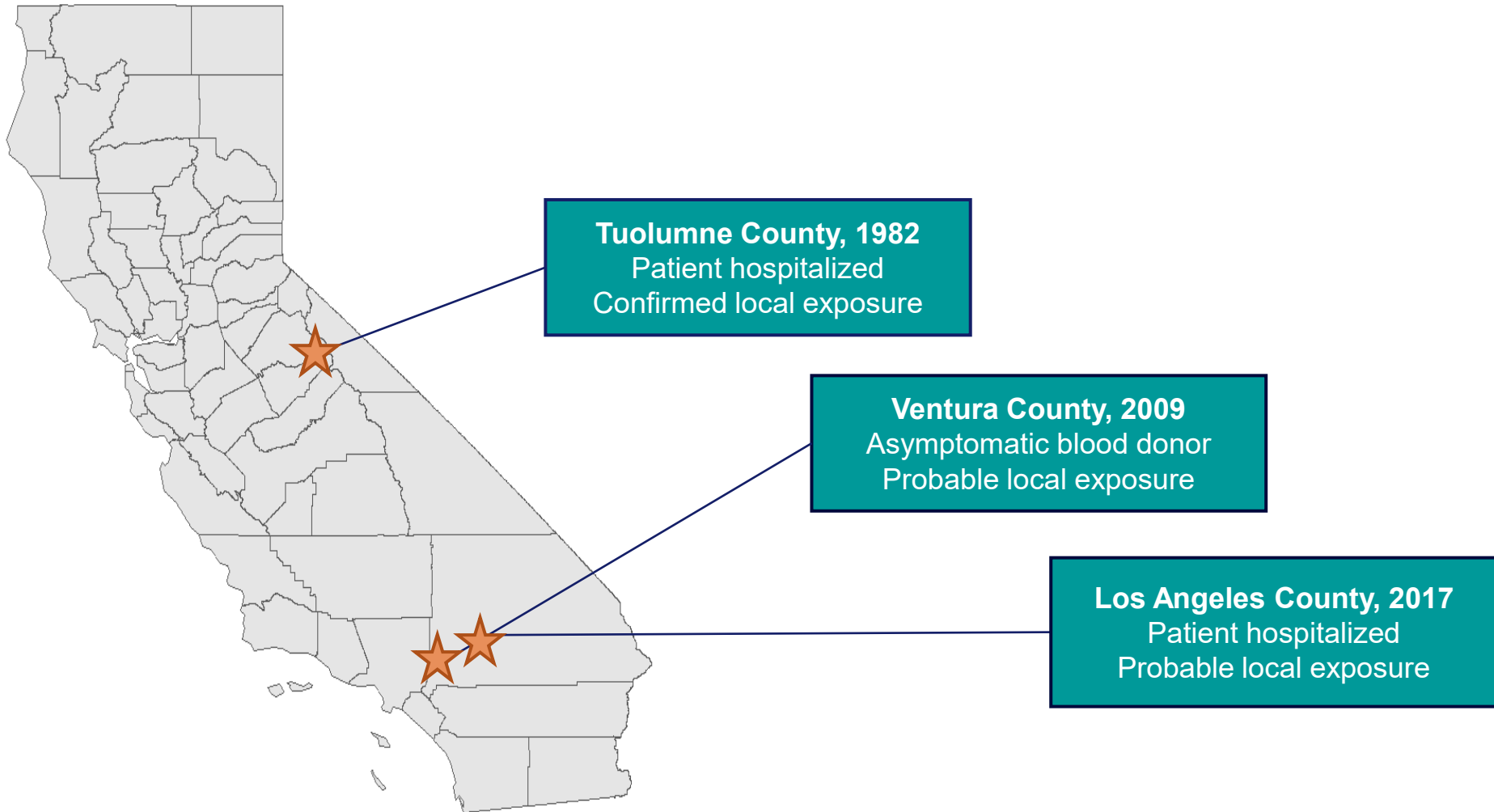

# Public Health Significance of *Triatoma protracta*

- ***Triatoma* bite hypersensitivity is the primary public health concern in California and the USA**
- **Estimated 5-15% bite victims experience severe bite reactions**
- **Sensitized individuals can try to minimize exposure by making home less attractive (i.e., lights) and “bug proof”. Severe cases should consider relocation away from rural or suburban peripheries**





**Marco E. Metzger, Ph.D.**  
**Vector-Borne Disease Section**  
**California Department of Public Health**  
**(909) 937-3448**  
**[Marco.Metzger@cdph.ca.gov](mailto:Marco.Metzger@cdph.ca.gov)**